

EnergyPack

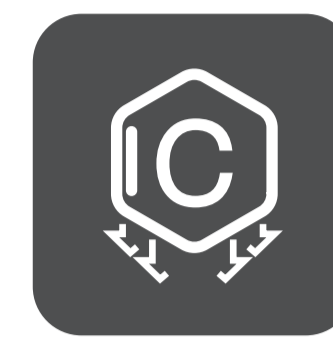

ZERO EMISSIONS



ZERO NOISE



PEAK SHAVING



LOAD SHARING



PLUG&PLAY



RENEWABLES INTEGRATION

PERFORMANCE		P200	P200 MAX
Nominal rated power	kVA	200	270
Overload power(60s)	kVA	250	337
Nominal peak power(10s)	kVA	600	750

ELECTRICAL		P200	P200 MAX
Rated voltage	VAC	415	
Output voltage range	VAC	400 (-10%~+15%)	
Frequency	Hz	50(60)	
Power factor range		0 ind. ...1 ... 0 cap	
Nominal AC current	A	278	376
Max AC current(10s)	A	835	1043

ENERGY		P200	P200 MAX
Cell chemistry		LiFePO4	
Nominal capacity	kWh	204	272
Effective capacity	kWh	183.6	244.8
Recharging time	Hours	2h@102kW	2h@136kW
Discharging time	Hours	1h@184kW	1h@245kW
System round trip efficiency	%	up to 96.6%	
DoD% (depth of discharge)	%	90	
Lifetime (80% DoD)	Cycles	7000	
Battery management system		Automotive grade BMS	
Temperature control		Liquid cooling / PI heating film	

ENVIRONMENTAL		P200	P200 MAX
Protection class		IP54	
Corrosion protection		C3 (C5M)	
Operating temperature	°C	-20 to +50	
Humidity		0-95% (no condensation)	
Maximum operating altitude	m	3000	
Sound power level	dB(A) @1m	<50	

MECHANICAL		P200	P200 MAX
Dimensions (L x W x H)	mm	2950*2300*2500	
Weight	kg	4800	6000

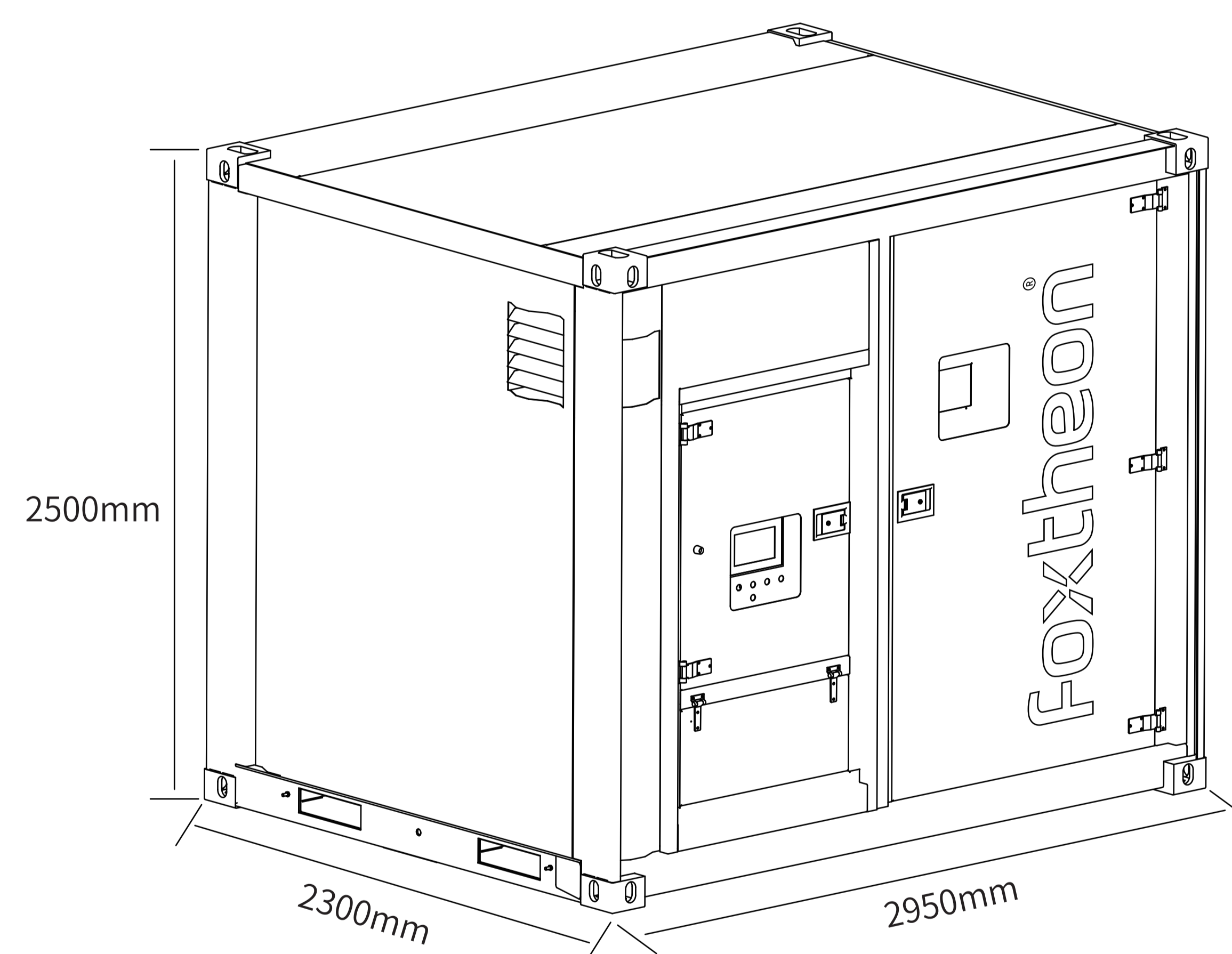

SCOPE OF SUPPLY

Canopy

- High strength structure, high IP protection container

Security

- Internal locker for batteries.
- Anti-theft hinges and door lockers.
- Earth pin without grounding rod.

Transportability

- Transport Efficiency: The design includes a lifting eye, skid frame with forklift pockets, anti-theft features.

OPTIONALS

- Custom colors
- Custom sockets distribution (input and output)
- Extended galvanized baseframe
- Integrated mains control
- Integrated PV inverter
- EV Charge point
- STS panel
- Trailer

CONTROL

Control panel	Industrial grade rugged 7" HMI with configurable presets, data visualisation and logs
Protection	Overload, Overheat, Short Circuit, Earth Fault
Temperature control	Active forced air cooling
Remote generator start	Dry contact relay / MODBUS
Remote connectivity	Data-efficient M2M communications via cellular IoT and user notifications to Internet connected devices
Remote automation	FoxCloud Web APP

FoxMind Energy Management System

FoxMind EMS is an intelligent hybrid power management system that automatically controls power distribution between generator, battery storage, PV, and mains systems, determining the most economical mix of power management of the whole system. It provides a simple and guided operation experience in choosing the appropriate working mode for any scenario, ensuring you a safe, efficient, and reliable energy supply.



Multiple Working Mode

Provides multiple operating modes selection for different working scenarios. The full functions EMS supports Island mode, Automatic Mains Failure, Fixed power, Peak shaving, Load take-over, Mains power export etc.



Integration Capability

The FoxMind EMS can automatically integrate various energy sources of generator, battery storage, PV, mains and provide seamless power switch.

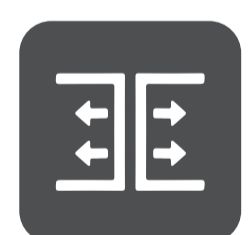

Scalability

The power and capacity can be expanded by paralleling with multiple EnergyPack BESS and generators.

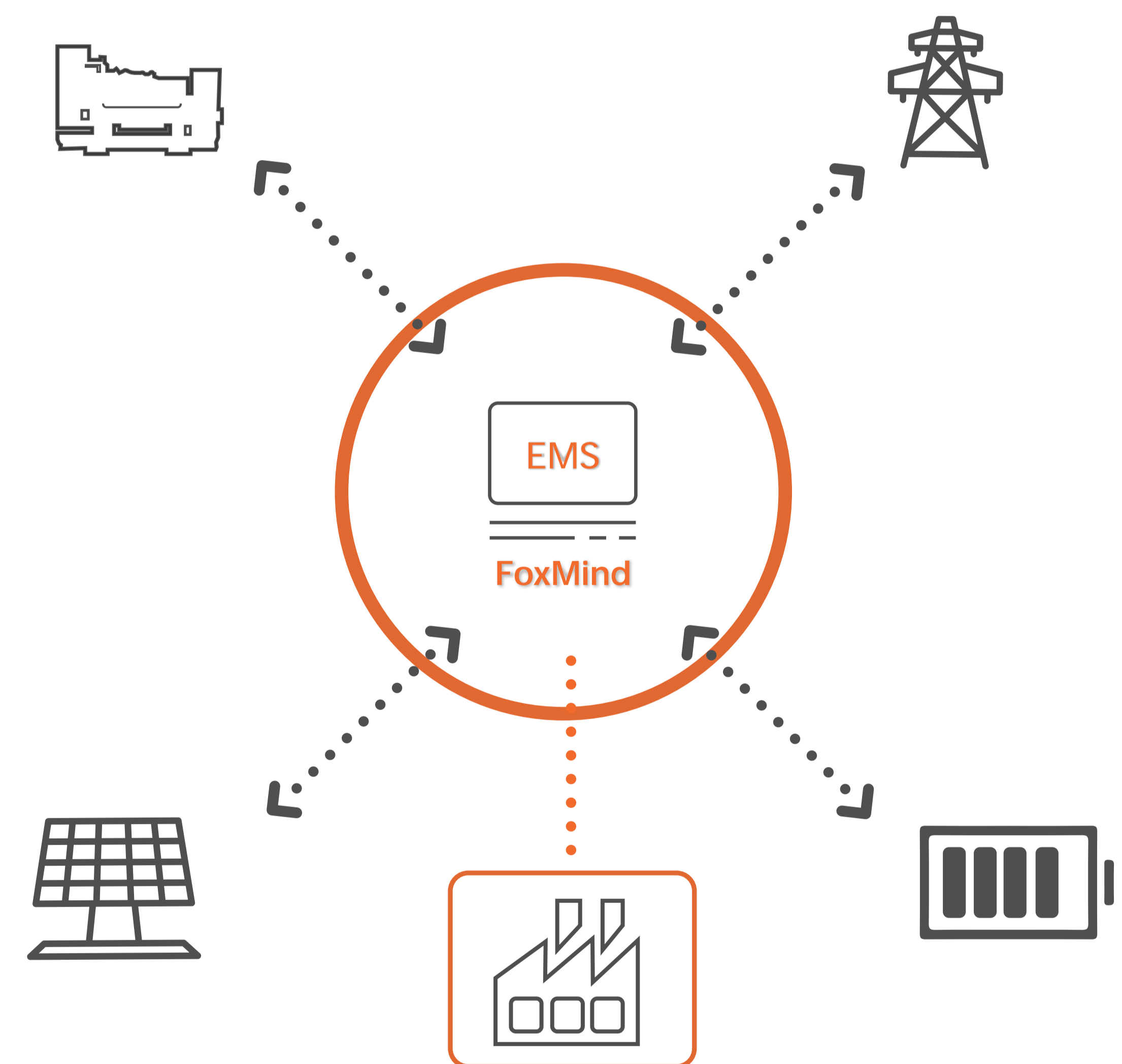

* Foxtheon has the right to modify any feature without prior notice. The images are indicative and may not coincide in their entirety with the product. Images non contractual.

Web: www.foxtheon.com

E-mail: info@foxtheon.com

Address: Hi-tech Zone Haixiyuan, Fuzhou, China